

**ACTIVITY SHEET – July - 2023**

**Time: 3 Hours**

**SSC - English (LL)**

**Marks: 80**

---

**SECTION I: Language Study - 10 marks**

**Q.1. (A) Do as directed. (Attempt any *four*):** **(8 marks)**

**(1) Complete the words by using correct letters:** **(2)**

- (i) enj\_y
- (ii) mon\_y
- (iii) w\_nder
- (iv) fo\_us

**(2) Put words in alphabetical order:** **(2)**

- (i) marriage, childhood, results, habits
- (ii) troop, talent, tired, taget

**(3) Punctuate the following sentences:** **(2)**

- (i) she said lets chat
- (ii) whats that said kamal kishore

**(4) Make *four* words (minimum of *three* letters each) using the letters in the word: 'INTERNATIONAL'.** **(2)**

**(5) Write the related words as shown in the example:** **(2)**

---

**[SSC ACTIVITY SHEET JULY 2023 With ANSWERSHEET](#)**

**ACTIVITY SHEET - July - 2023**

**Time: 3 Hours SSC - English (LL) Marks:**

**80**-----

**SECTION I: Language Study - 10 marks**

**Q.1. (A) Do as directed. (Attempt any four): (8 marks)**

**(1) Complete the words by using correct letters: (2)**

(i) enj\_y

(ii) mon\_y

(iii) w\_nder

(iv) fo\_us

**(2) Put words in alphabetical order: (2)**

(i) marriage, childhood, results, habits

(ii) troop, talent, tired, taget

**(3) Punctuate the following sentences: (2)**

(i) she said lets chat

(ii) whats that said kamal kishore

**(4) Make four words (minimum of three letters each) using the letters in the word:**

**'INTERNATIONAL'. (2)**

**(5) Write the related words as shown in the example: (2)**

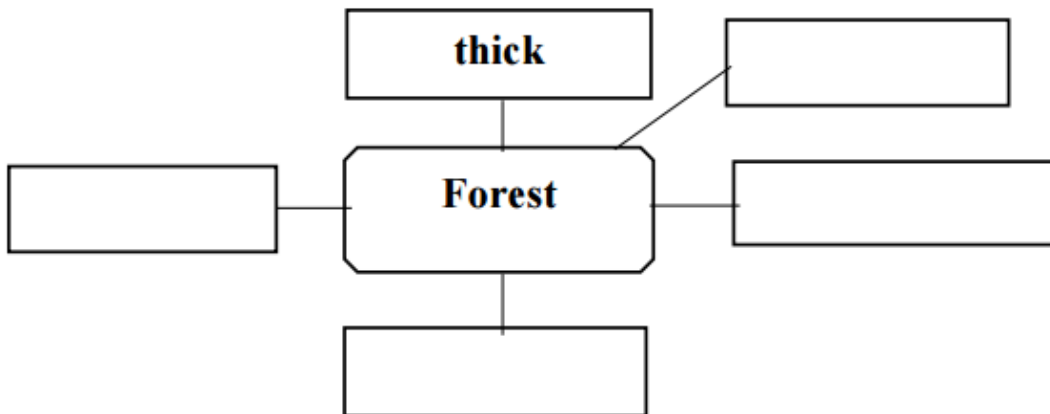

**(6) Complete the word chain of 'nouns. Add four words, each beginning with the last**

**letter of the previous word: (2)**

**bank ..... ..**

**(B) Do as directed: (2 marks)**

**(1) Attempt any one:**

**(a) Make a meaningful sentence by using the phrase: 'in front of' (1)**

**OR**

**(b) Add a clause to the following sentence to expand it meaningfully:**

I wondered.

**(2) Attempt any one:**

**(a) Add a prefix or suffix to make new words: (1)**

(i) lucky

(ii) change

**OR**

**(b) Make a meaningful sentence using any one of the following words:**

(i) lucky

(ii) change

**SECTION II: Textual Passages - 20 marks**

**Q. 2. (A) Read the following passage and do the activities. (10 marks)**

**A1. Write whether the following sentences are 'True' or 'False': (2)**

(i) To accomplish goals, experts recommend a ten-step approach.

(ii) The champions have to have the skill and the will.

(iii) For anyone, setting goal is not easy but challenging.

(iv) If we do not take action to achieve goals, we shall not achieve goals.

Champions aren't made in gyms. Champions are made from something they have deep inside them - a desire, a dream, a vision. They have to have the skill and the will. But the will must be stronger than the skill. Successful professionals thrive in the same manner. We all have natural talents. If we use that talent to set our goal in life, we can easily get success in life. We shall not achieve our goals if we do not take action to achieve them. Setting goals has two valuable assets - a sense of originality and a stepping stone to illuminate the path. Goals put one at the helm of life; pursuing them acknowledges a better future situation. They help to steer a course of life rather than simply drifting along and letting things happen.

Setting goals may appear easy, but, for some, it is quite challenging. Fear of failure may be avoided in the absence of any goals. After all, one has to decide what one wants to achieve in the end. To accomplish goals, experts recommend a five-step approach.

**A2. Complete the web diagram: (2)**

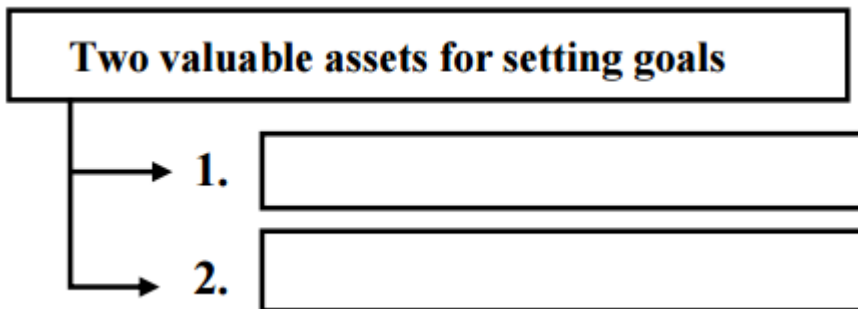

**A3. (1) Pick out any two adverbs from the passage: (1)**

(i) .....

(ii) .....

**(2) Write adjectives of the following words: (1)**

(i) .....

(ii) .....

**A4. Do as directed: (2)**

(i) **The will must be stronger than the skill.**

**(Select the 'positive degree' from the following)**

- (a) The will must be as strong as the skill.
- (b) The will must not be as strong as the skill.
- (c) The skill must not be as strong as the will.
- (d) The skill must be as strong as the skill.

**(ii) They have to have the skill and the will.**

(Use 'not only .....but also')

**A5. Personal Response: (2)**

**Write your any one goal and what do you do to achieve it?**

**(B) Read the following passage and do the activities: (10 marks)**

**B1. Fill in the blanks and complete the sentences: (2)**

- (i) Mary Kom conquered the.....
- (ii) She was the first .....woman boxer to qualify and win a bronze medal in the 51 kg flyweight category of Boxing.
- (iii) Since childhood Mary had an eager interest in.....
- (iv) The father and mother of Mary Kom were.....

There had to be one successful story if Indians were to survive in sports and we have that story now. Enough has been said about this great warrior who conquered the world. This warrior is none other than Mary Mangte Kom - the Komqueror and the Komrade. She is famed as a five times World Boxing Champion and the only boxer to win a medal in every one of the six world championships. In the 2012 Olympics, she became the first Indian woman boxer to qualify and win a bronze medal in the 51 kg flyweight category of Boxing.

Kom was born in Kangthei village, Moirang Lamkhai in Churachandpur district of rural Manipur in eastern India. She came from a poor family. Her parents, Mangte Tonpa Kom and Mangte Akham Kom were tenant farmers who worked in jhum fields. Kom grew up in humble surroundings, helping her parents with farm related chores, going to school and learning athletics initially and later boxing simultaneously. Her father was a keen wrestler in his younger age. She had an eager interest in athletics since childhood.

**B2. Make a list of achievement of Mary Kom as a boxer. (Any two) (2)**

**B3. Fill in the blanks by selecting words or phrases from the passage: (2)**

(i) My younger sister has so much.....in dancing and singing.

(ii) Tanaji Malusare was a great.....in history.

**B4. Do as directed: (2)**

(i) Mary Kom was a warrior. She was a boxer.

**(Use 'as well as')**

(ii) Her father was a keen wrestler in his young age.

**(Pick out and rewrite two adjectives from the given sentence)**

**B5. Personal Response**

**Write any two names of indoor games and two names of outdoor games. (2)**

**SECTION III: Poetry - 10 marks**

**Q. 3. (A) Read the following stanzas and do the activities: (5 marks)**

**A1. Choose the correct alternatives: (2)**

(i) The poet has stopped in the.....

**(village/city)**

(ii) The season of the year is.....

**(winter/summer)**

(iii) The time of the day is .....

**(evening/morning)**

(iv) Between the woods and the frozen.....is the darkest evening of the year.

Whose woods these are I think I know.  
His house is in the village, though;  
He will not see me stopping here  
To watch his woods fill up with snow.  
My little horse must think it queer  
To stop without a farmhouse near  
Between the woods and frozen lake  
The darkest evening of the year.  
He gives his harness bells a shake  
To ask if there is some mistake.  
The only other sound's the sweep  
Of easy wind and downy flake.  
The woods are lovely, dark and deep,  
But I have promises to keep,  
And miles to go before I sleep,  
And miles to go before I sleep.

**A2. Find lines from the extract for the following. (2)**

(i) His horse seems anxious to keep going.

.....

(ii) The speaker prefers to stay but is forced to move onwards.

.....

**A3. Write your own rhyming words for the following: (1)**

(i) near .....

(ii) shake .....

**(B) Appreciation of the poem: (5 marks)**

**Read the following poem and write an appreciation of it with the help of the points given below:**

**The Twins**

In form and feature, face and limb,  
I grew so like my brother,  
That folks got taking me for him,  
And each for one another.  
It puzzled all our kith and kin,  
It reached a fearful pitch;  
For one of us was born a twin,  
Yet not a soul knew which.  
One day, to make the matter worse,  
Before our names were fixed,  
As we were being washed by nurse,  
We got completely mixed;  
And thus, you see, by fate's decree,  
Or rather nurse's whim,  
My brother John got christened me,  
And I got christened him.

This fatal likeness even dogged  
My footsteps, when at school,  
And I was always getting flogged,  
For John turned out a fool.  
I put this question, fruitlessly,  
To everyone I knew,  
'What would you do, if you were me,  
To prove that you were you?'  
Our close resemblance turned the tide  
Of my domestic life,  
For somehow, my intended bride  
Became my brother's wife.  
In fact, year after year the same  
Absurd mistakes went on,  
And when I died, the neighbours came  
And buried brother John  
**Henry Sambrooke Leigh**

(1) Title - (½)

(2) Name of the poet - (½)

(3) Rhyme scheme - (1)

(4) Figures of speech (Any one) - (1)

(5) Theme/Central idea (in 2 to 3 lines) (2)

**SECTION IV: Non-Textual Passage - 15 marks**

**Q.4. (A) Read the following passage and do the activities: (10 marks)**

**A1. Fill in the blanks: (2)**

(i) We have humps to store ..... for desert journeys

(ii) Eyelashes are the ..... covers the eyes.

(iii) One day, a camel and her baby were .....

(iv) Rounded feet are meant to help us walk.....in the desert.



One day, a camel and her baby were chatting. The baby asked, "Mother, why do we have humps?" The mother replied, "Our humps are for storing water so that we can survive in the desert". "Oh", said the child, "and why do we have rounded feet mother?" "Because they are meant to help us walk comfortably in the desert. These legs help us move around in the sand."

"Alright. But why are our eyelashes so long?" "To protect our eyes from the desert dust and sand. They are the protective covers for the eyes", replied the mother camel. The baby camel thought for a while and said, "So we have humps to store water for desert journeys, rounded hooves to keep us comfortable when we walk in the desert sand, and long eyelashes to protect us from sand and dust during a desert storm. Then what are we doing in a zoo?"

The mother was dumbfounded.

**A2. Complete the following table: (2)**

<b>Limbs of the camels</b>	<b>Different uses in the desert</b>
<b>1. Rounded feet</b>	.....
<b>2. Eyelashes</b>	.....

**A3. Match the synonym: (2)**

'A' 'B'

- (i) kid (a) storm
- (ii) tempest (b) baby
- (iii) answered (c) speechless
- (iv) dumb (d) replied

**A4. Do as directed: (2)**

**(i) They are the protective covers for the eyes.**

(Choose the correct 'question tag')

- (a) are they?

(b) aren't they?

(c) do they?

(d) doesn't they?

**(ii) These legs help us move around in the sand.**

(Make 'Present Continuous Tense)

### **A5. Personal Response**

Would you like to visit the zoo? Why? (2)

**(B) Summary Writing: (5 marks)**

Read the passage given in Q. No. 4 (A) and write a summary of it.

Suggest a suitable title to the summary.

### **SECTION V: Writing Skills - 20 marks**

**Q. 5. (A) Letter writing:**

**A1 or A2. Do any one of the following activities: (5 marks)**

Imagine you are Swapnil/Swapnali Patil, residing at Balaji Nagar, Omerga. Read the following advertisement regarding tree plantation campaign. Now attempt any one letter from the following:

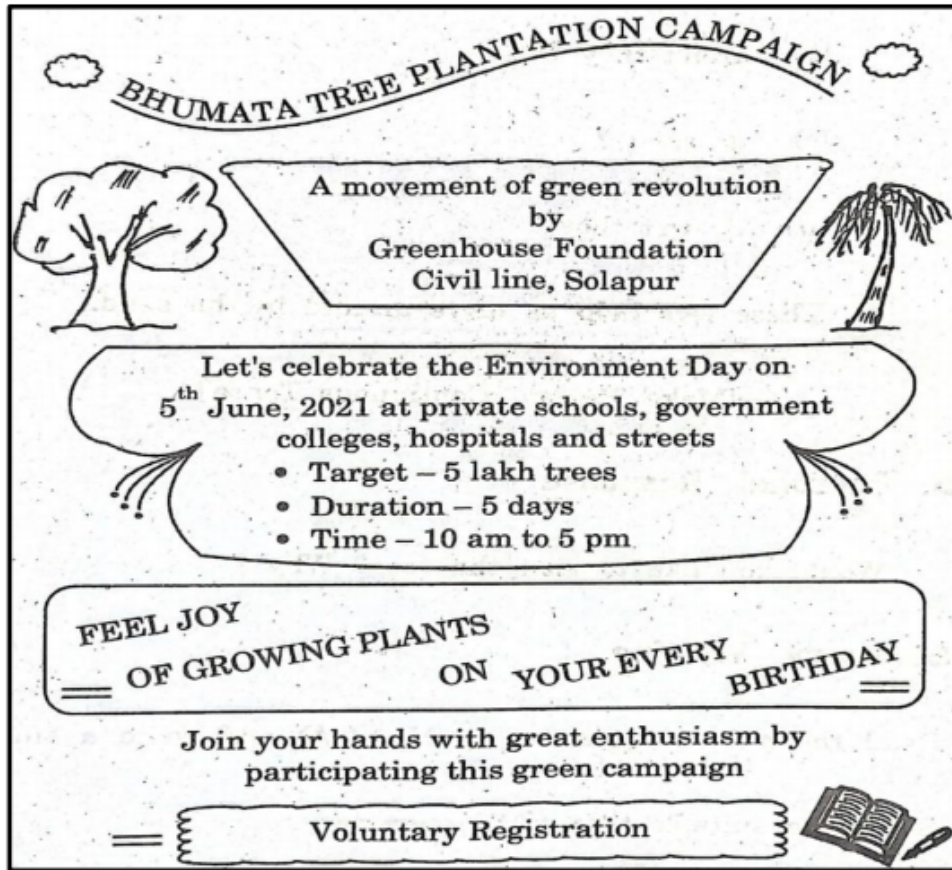

<b>A1. Informal Letter</b>		<b>A2. Formal Letter</b>
Write a letter to your sister encouraging and informing her about the 'Tree plantation Campaign'. Tell her the usefulness and advantages of it. Add your own points	<i>Or</i>	Write a letter to the Director, Greenhouse, Foundation, Solapur requesting him/her to register your school name for making this campaign successful. ❖ Make enquiry in detail about it. ❖ Add your own points.

**(B) B1 or B2. Dialogue writing/ Drafting a speech: (5 marks)**

**B1. Dialogue writing:**

**(a) Prepare a dialogue from the jumbled sentences: (1)**

- (i) I use it whenever I go to the public places.
- (ii) Do you know the importance of washing hands?

(iii) Arun, when do you use a mask?

(iv) Yes, I know, it's necessary.

**(b) Complete the dialogue: (1)**

**Anil:** Do you like social service?

**Sunil:** .....

**Anil :** Who is your favourite social reformer?

**Sunil:** .....

**(c) Write a dialogue between you and your friend having three meaningful exchanges on**

**'The Importance of Competitive Examination'. (3)**

**OR**

**B2. Drafting a speech:**

**You are going to participate in an Inter-school Elocution Competition arranged by the Raman Science Centre. Write a speech on "The role of science in the progress of the nation" with the help of the following points:**

- Science makes our life smooth and comfortable.
- It saves time and energy.
- Need of the future.
- Explore the new techniques and inventions.
- It should be used for the peace and progress.
- Science is boon as well as curse.

**Q. 6. (A) Information Transfer:**

**A1 or A2. Do any one of the following activities: (5 marks)**

**A1. Non-verbal to verbal:**

Read the information given in the following tree-diagram and write two short paragraphs based on it. Give a suitable title to your write up.

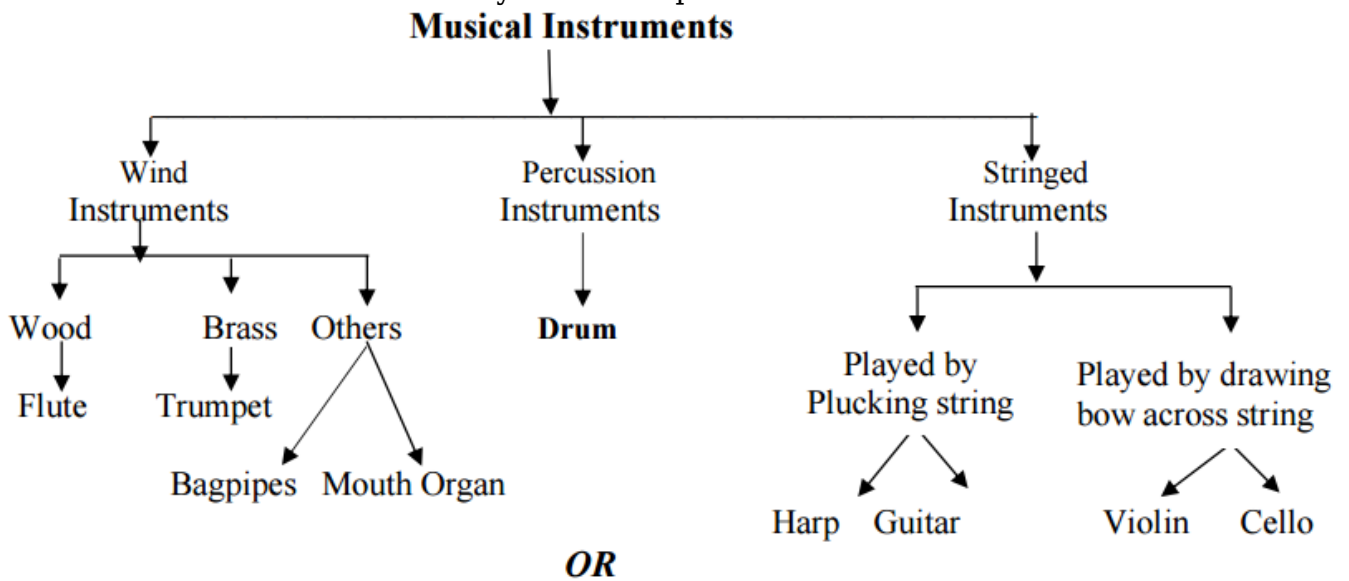

**A2. Verbal to Non-verbal:**

Read the following information and present it in the tree diagram given below. Give a suitable title to it.

Oil is necessary in the nutrition of our body, but the excess use of oil should be avoided. There are three types of oils. They are groundnut oil, vegetable oil and mineral oil. Groundnut oil is prepared from groundnuts which we use for eating. It is also used in cooking food. Vegetable oil is prepared from grains. It is also used for making soups, medicines and scents. Its medicinal uses have made it so valuable. The third type of oil is mineral oil, which is obtained from the crust of the earth. We use it for driving machines and in the industry also.

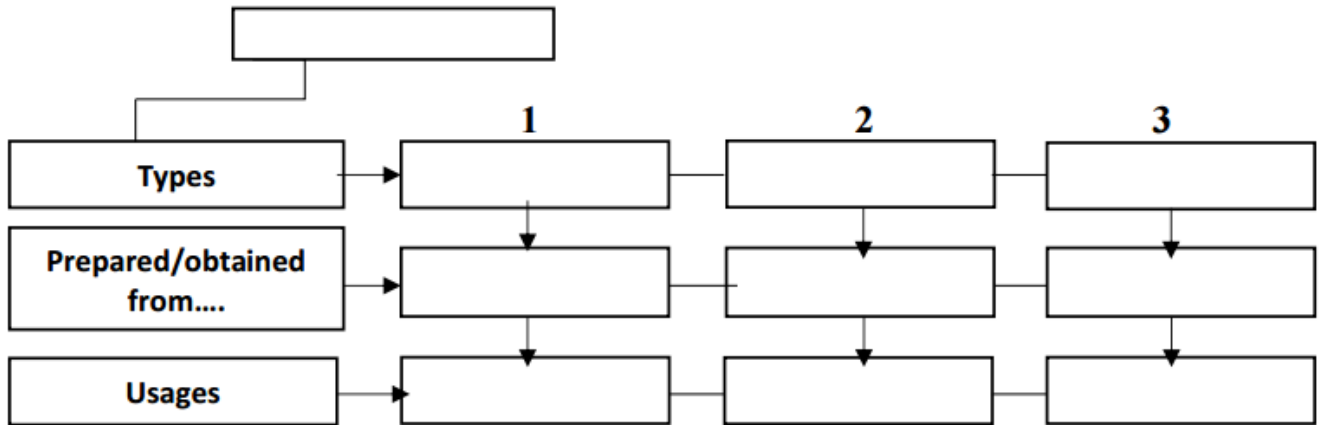

**(B) Expand the theme:**

**B1 or B2. Do any one of the following activities: (5 marks)**

**B1. News Report**

**Read the following headline and prepare a news report with the given points:**

Ten year child saved a drowning girl

- **Headline**
- **Date line**
- **Introduction**
- **Short continuing paragraph**

**OR**

**B2. Developing a story:**

**Develop a story with the help of the given beginning. Suggest a suitable title.**

.....  
 .....

.....**The crow**

**Drank water and flew away happily.**

**SECTION VI: Skill Development - 5marks**

**Q. 7 Translation: (5 marks)**

**(a) Translate the following words into your medium of instruction. (Any four) (2)**

- (1) Faith
- (2) Taste
- (3) Advance
- (4) Easily
- (5) Reaction
- (6) Atmosphere

**(b) Translate the following sentences into your medium of instruction. (Any two) (2)**

- (1) Wash your hands regularly.
- (2) Use mask for safety.
- (3) Stay away from crowd.
- (4) Be careful, life is precious.

**(c) Translate the following idioms/ proverbs into your medium of instruction. (Anyone)**

- (1) Man is the slave of his habits.
- (2) Hard work is the key to success.

## **Answer -Sheet**

### **ACTIVITY SHEET - July - 2023**

**Time: 3 Hours SSC - English (LL) Marks:**

**80**-----

#### **(1) Complete the words by using correct letters:**

(i) enjoy

(ii) money

(iii) wonder

(iv) focus

#### **(2) Put words in alphabetical order:**

(i) childhood, habits, marriage, results

(ii) target, talent, tired, troop

#### **(3) Punctuate the following sentences:**

(i) She said, "Let's chat."

(ii) "What's that?" said Kamal Kishore.

#### **(4) Make four words (minimum of three letters each) using the letters in the word:**

**'INTERNATIONAL'.**

1. Train,
2. Iron,
3. later,
4. nation



**(5) Write the related words as shown in the example:**

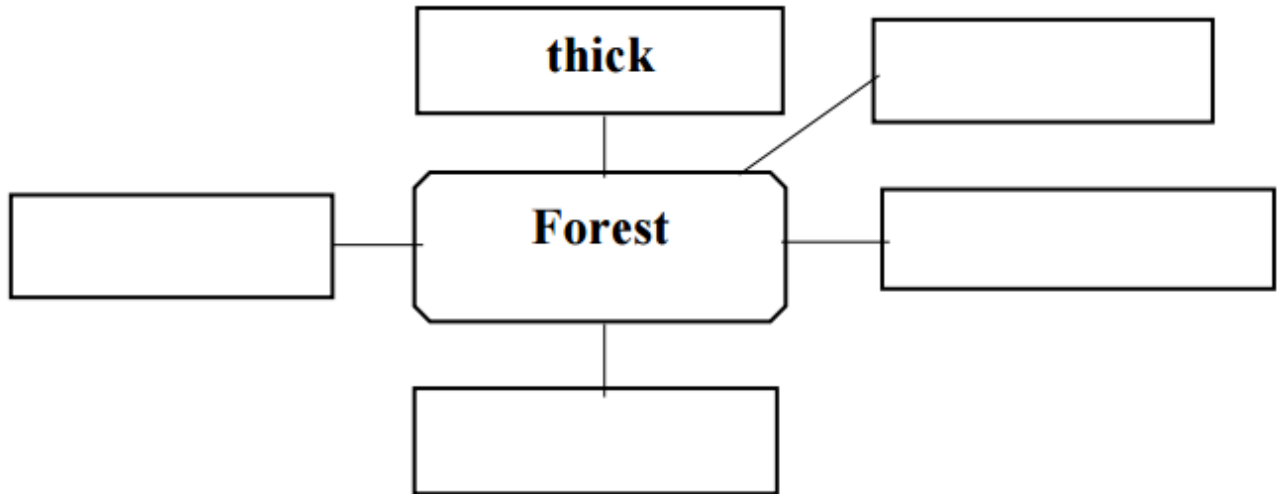

1. Beautiful, 2. Attractive, 3. Seren, 4. Enchanting, 5. dense

**(6) Complete the word chain of 'nouns'. Add four words, each beginning with the last**

**letter of the previous word:**

**bank:** kettle - elephant - table - eagle

**(B) Do as directed:**

**(1) Attempt anyone:**

**(a) Make a meaningful sentence by using the phrase: 'in front of'**

"The cat sat **in front of** the Mango tree."

**(b) Add a clause to the following sentence to expand it meaningfully:**

I wondered **what had happened to my friend.**

**(2) Attempt any one:**

**(a) Add a prefix or suffix to make new words:**

(i) lucky: **unlucky**

(ii) change: **changeable**

**OR**

**(b) Make a meaningful sentence using any one of the following words:**

**(i) lucky:** She felt **lucky** to find her lost keys.

**(ii) change:** The **change** in weather brought about a noticeable drop in temperature.

**SECTION II: Textual Passages - 20 marks**

**Q. 2. (A) Read the following passage and do the activities. (10 marks)**

**A1. Write whether the following sentences are 'True' or 'False':**

(i) To accomplish goals, experts recommend a ten-step approach. - **False**

(ii) The champions have to have the skill and the will. - **True**

(iii) For anyone, setting a goal is not easy but challenging. - **False**

(iv) If we do not take action to achieve goals, we shall not achieve goals. - **True**

**A2. Complete the web diagram:**

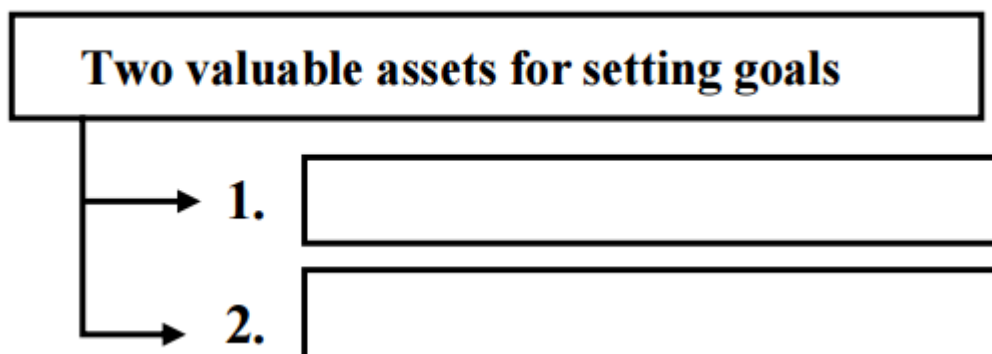

1. **A sense of originality:**

2. **A stepping stone to illuminate the path:**

**A3.**

**(1) Two adverbs from the passage:**

**(i) easily**

**(ii) simply**

**(2) Adjectives of the following words:**

(i) easy - **easier**

(ii) challenging - **challenging**

**A4.**

**(i) The will must be stronger than the skill.**

- Positive degree: **(c) The skill must be not as strong as the will.**

**(ii) They have to have the skill and the will.** (Using 'not only... but also')

They have to have **not only** the skill, **but also** have the will.

**A5. Personal Response:**

**Write your any one goal and what do you do to achieve it?**

**Ans:**

Being a 10th standard student, this year my goal is to accomplish above 95% marks in his ssc board exam. For that I will study hard, I will make study plan of day, weekly & monthly. I will take my subject teachers help to clear my doubts.

**(B) Read the following passage and do the activities:**

**B1. Fill in the blanks and complete the sentences:**

(i) Mary Kom conquered **the world**.

(ii) She was the first **Indian** woman boxer to qualify and win a bronze medal in the 51 kg

flyweight category of Boxing.

(iii) Since childhood Mary had an eager interest in **athletics**.

(iv) The father and mother of Mary Kom were **tenant farmers who worked in jhum fields**.

**B2. Make a list of achievement of Mary Kom as a boxer. (Any two)**

i) Five-time World Boxing Champion

ii) The only boxer to win a medal in every one of the six world championships

**B3. Fill in the blanks by selecting words or phrases from the passage:**

(i) My younger sister has so much **interest** in dancing and singing.

(ii) Tanaji Malusare was a great **warrior** in history.

**B4. Do as directed:**

(i) Mary Kom was a warrior **as well as** a boxer.

(ii) Her father was a **keen, young** wrestler.

**B5. Personal Response**

**Write any two names of indoor games and two names of outdoor games**

**Two indoor games:**

1. Chess
2. Table tennis

**Two outdoor games:**

1. Football
2. Tennis

**SECTION III: Poetry - 10 marks**

**Q. 3. (A) Read the following stanzas and do the activities:**

**A1. Choose the correct alternatives:**

- (i) The poet has stopped in **the village**.
- (ii) The season of the year is **winter**.
- (iii) The time of the day is **evening**.
- (iv) Between the woods and the frozen **lake** is the darkest evening of the year.

**A2. Find lines from the extract for the following:**

- (i) His horse seems anxious to keep going.

**Line: "He gives his harness bells a shake."**

- (ii) The speaker prefers to stay but is forced to move onwards.

**Line: "But I have promises to keep."**

**A3. Write your own rhyming words for the following:**

- (i) near - dear
- (ii) shake - lake

**(B) Appreciation of the poem:**

**Read the following poem and write an appreciation of it with the help of the points given below:**

**Appreciation of the poem The Twins.**

- **Title:** - The Twins.
- **Poet/Poetess:** - Henry Sambrooke Leigh.
- **Rhyme scheme:** - ababcdcd.

• **Figures of Speech:** - The poet uses the following figures of speech in this poem.

(i) Alliteration.

(ii) Hyperbole.

(iii) Pun.

• **Theme/Central idea:** - The central theme of the poem is the physical resemblance shared by identical twins that it can create confusion among the people. It shows the problems faced by the twins as well as families and friends in identifying one from the other.

#### **SECTION IV: Non-Textual Passage -**

**Q.4. (A) Read the following passage and do the activities:**

**A1. Fill in the blanks:**

(i) We have humps to store **water** for desert journeys.

(ii) Eyelashes are **the protective** covers for the eyes.

(iii) One day, a camel and her baby were **chatting**.

(iv) Rounded feet are meant to help us walk **comfortably** in the desert.

**A2. Complete the following table:**

**Limbs of the camels Different uses in the desert**

1. Rounded feet            **Aid in comfortable walking on desert sand**

2. Eyelashes                **Protect eyes from sand and dust**

**A3. Match the synonym:**

(i) kid - **(b) baby**

(ii) tempest - **(a) storm**

(iii) answered - **(d) replied**

(iv) dumb - **(c) speechless**

**A4. Do as directed:**

(i) They are the protective covers for the eyes.

**(Choose the correct 'question tag')**

**(b) aren't they?**

(ii) These legs help us move around in the sand.

**(Make 'Present Continuous Tense')**

**These legs are helping us move around in the sand.**

**A5. Personal Response**

**Would you like to visit the zoo? Why?**

"Visiting the zoo is fun for me. I get to see animals which I don't usually see. It's like a school where I learn about animals and how they live. I can ask questions and watch shows about animals. It's a good place to play and be outside."

**(B) Summary Writing:**

**Read the passage given in Q. No. 4 (A) and write a summary of it.**

**Suggest a suitable title to the summary**

**Title: "Camel Conversations: Life in the Desert"**

**Summary:**

A baby camel asks its mom about their humps, feet, and long eyelashes. Mom says humps store water, feet help in walking comfortably, and eyelashes protect their eyes. Baby wonders why they're in a zoo, leaving mom surprised.

Note: The summary tells about the camel conversation, explaining how they survive in the desert and questioning their zoo life.

## **SECTION V: Writing Skills**

### **SECTION V: Writing Skills**

#### **5. 5. (A) Letter writing:**

##### **A1. Informal Letter.**

Swapnil Patil.

Balaji Nagar,

Omerga 413606.

1<sup>st</sup> June 2021.

Dear Didi,

How are you? I hope you will be well and good.

Yesterday I saw an advertisement regarding the Tree Plantation Campaign. It impressed me a lot. So I would like to share it with you.

There is a Tree Plantation Campaign happening soon, and I think it's a fantastic way to help our environment.

It's called the Bhumata Tree Plantation Campaign by the Greenhouse Foundation in Solapur. It is going to start on 5th June at private schools, colleges, hospitals, and streets. They want to plant approximately 5 lakh trees in just 5 days, from 10 am to 5 pm.

The best part? They're saying we can celebrate our birthdays by planting trees. Imagine having a tree grow along with you every year, it's pretty cool, right?

Trees do a lot of good things like giving us fresh air, supporting animals, and keeping our environment healthy. By planting trees, we can make a real difference in our area and for the planet.

I think it would be awesome if we joined in. It's a chance to do something good for the world, learn about why trees are important, and be a part of our community.

I'm planning to be there, and I'd love for you to join me. Let's make our neighbourhood



greener and happier together.

Hope to see you there!

Yours loving,

Swapnil.

## **A2. Formal Lette.**

Swapnil Patil.

Balaji Nagar,

Omerga 413606.

1st June 2021.

### **To.**

Director.

Greenhouse Foundation

Civil Line,

Solapur 413007.

**Subject:** Request for School Registration in Bhumata Tree Plantation Campaign

**Dear Sir,**

I hope you're doing well. Our school, [Your School Name], is excited about joining your Tree Plantation Campaign in Solapur.

We're eager to participate in it. So we need some information about how our school can sign up. Could you let us know the steps we need to follow and any forms we need to fill? We want to make sure we're all set to join in planting the 5 lakh trees.

We love the idea of celebrating birthdays by planting trees. It fits perfectly with our school's goal of teaching students about taking care of our environment.

We're committed to making this campaign successful. Your guidance and support for our school's involvement would mean a lot to us.

Thank you for your time. We're looking forward to being a part of this great initiative.

**Sincerely,**

Swapnil Patil.

Std. 10<sup>th</sup> Class Monitor

Vidyadeep Vidyalaya.

**(B) B1 or B2. Dialogue writing/ Drafting a speech:**

**B1. Dialogue writing:**

**(a) Dialogue from jumbled sentences:**

**Arun:** Do you know the importance of washing hands?

**Person:** Yes, I know, it's necessary.

**Arun:** When do you use a mask?

**Person:** I use it whenever I go to public places.

**(b) Complete the dialogue:**

**Anil:** Do you like social service?

**Sunil:** Yes, I like social service

**Anil:** Who is your favourite social reformer?

**Sunil:** My favourite social reformer is Karmveer Bhaurao Patil.

**(c) Write a dialogue between you and your friend having three meaningful exchanges on 'The Importance of Competitive Examination'.**

**'The Importance of Competitive Examination'.**

**You:** Hey, have you been thinking about competitive exams?

**Friend:** Yeah, I have. I feel they're pretty important. They open doors to various opportunities and help us to decide our career.

**You:** Definitely! They not only test our knowledge but also teach us discipline and time management, which are crucial skills for life.

**Friend:** Plus, competitive exams push us to keep learning and improving. They're like a stepping stone towards achieving our goals and aspirations.

**You:** Absolutely, they may be challenging, but the experience gained from preparing for and taking these exams is invaluable.

**Friend:** Agreed. They're like a roadmap, guiding us towards our future and shaping us into more capable individuals.

**B2. Drafting a speech:**

**"The role of science in the progress of the nation"**

Respected judges, teachers, and my dear friends.

Imagine a world without science - no smartphones, no medicine, no electricity. We owe a lot to science for making our lives comfy and easy. It's like our superhero, saving time and energy with all its cool inventions.

Think about tomorrow - science is what we need. It keeps on finding new ways to make things better and cooler. But here's the deal: science can be both awesome and scary. It's

like a double-edged sword, bringing good stuff but also things we need to be careful about.

So, let's not just focus on what science can do, but on how we use it. We've got to be responsible with all this power. It's not just about progress; it's about using science for the good of everyone.

Science isn't just about labs and formulas; it's about making life better for all of us. Let's make sure we're using it in ways that help us move forward while keeping the peace. That's the real power of science - making life awesome for everyone.

Thank you!

#### **6. 6. (A) Information Transfer:**

**A1 or A2. Do any one of the following activities: (5 marks)**

**A1. Non-verbal to verbal:**

**Title: "The Variety of Musical Instruments"**

Musical instruments come in different types: wind, percussion, and stringed. Wind instruments like the flute and trumpet make music by blowing air into them. Percussion instruments, such as drums, create beats and rhythms. Stringed instruments, like the guitar and violin, produce sound by either plucking or using a bow on strings.

These instruments give musicians lots of ways to create different kinds of music. Whether it's the strong sound of a trumpet or the gentle melodies of a flute, each instrument adds its unique touch to the world of music.

**A2. Verbal to Non-verbal:**

**Read the following information and present it in the tree diagram given below. Give a**

**suitable title to it.**

**(B) Expand the theme:**

**B1 or B2. Do any one of the following activities: (5 marks)**

**B1. News Report**

**Read the following headline and prepare a news report with the given points:**

**Ten-year child saved a drowning girl**

**By Staff Reporter.**

**Wednesday, 23rd October 2023, Solapur:**

A ten-year-old boy saved a six-year-old girl who was drowning in river. Yesterday, in Solapur, a 5th std school-going boy was roaming near the river. He saw a small girl aged around 6 years playing near the riverbank.

Suddenly the small girl went into the river to bring back her ball. She went deep inside and was trying to come back but couldn't. In the blink of an eye, she disappeared in the water.

The ten-year-old boy who was watching her just ran towards him without thinking twice. He swam with full force and grabbed the drowning girl. Then he brought the small girl on the bank of the river. Till then the people gathered there and admitted the small girl in the hospital. The ten-year-old became hero in the eyes of all.

**B2. Developing a story:**

**The Thirsty Crow**

One hot day, a thirsty crow flew all over the fields looking for water. For a long time, he could not find any. He felt very weak, and almost lost all hope. Suddenly, he saw a water jug below the tree. He flew straight down to see if there was any water inside. Yes, he could see some water inside the jug!

The crow tried to push his head into the jug. Sadly, he found that the neck of the jug was too narrow. Then he tried to push the jug to tilt for the water to flow out, but the jug was too heavy.

The crow thought hard for a while. Then, looking around it, he saw some pebbles. He suddenly had a good idea. He started picking up the pebbles one by one, dropping each into the jug. As more and more pebbles filled the jug, the water level kept rising. Soon it was high enough for the crow to drink. The crow drank water and flew away happily.

## SECTION VI: Skill Development -

### Q. 7 Translation:

**(a) Translate the following words into your medium of instruction. (Any four)**

(1) Faith : □□□□□□

(2) Taste : □□

(3) Advance: □□□□

(4) Easily: □□□

(5) Reaction: □□□□□□□□□□

(6) Atmosphere: □□□□□□□□

**(b) Translate the following sentences into your medium of instruction. (Any two)**

(1) Wash your hands regularly.

□□□□□□□□□□ □□□ □□□□.

(2) Use mask for safety.

□□□□□□□□□□□□□□ □□□□□ □□□□□.

(3) Stay away from crowd.

□□□□□□□□□□ □□□ □□□□.

(4) Be careful, life is precious.

□□□□ □□□, □□□□ □□□□□□□□ □□□.

**(c) Translate the following idioms/ proverbs into your medium of instruction. (Any one)**

(1) Man is the slave of his habits.

□□□□□ □□ □□□□□□□□ □□□□□□ □□□□□ □□□□□.

(2) Hardwork is the key to success.

□□□□□ □□ □□□□□ □□□□□□□□□□ □□□.

Please follow and like us:

